

Ahmet KARAARSLAN, Tolga ÖZER

Afyon Kocatepe University, Faculty of Technology, Department of Electrical-Electronic Engineering, Afyonkarahisar, Turkey

Implementation of remote control device using USB 1208LS

1. Introduction

The fact that accepted by everyone who in this sector or not is IT industry and depending on the communication sector how developed quickly. People requests increase in parallels with the rapid development and people begin to ask for more than they had before. In parallel with the rapid development of communication industry, control independently of the location desire is no longer prevented. People want to check out their homes' electronic goods even when they at the outside their houses. For example, people want to increase the degree of cooling the refrigerator or heating the meal in oven when they don't arrive at the home. In this way, many of the studies have been done in the field of smart homes. In the IT industry's computer systems can communicate with remote control.

After the computer came into our life and almost impossible keep up with the evolving technology in the world, existing technologies which have almost more or less in everyone's life combined with each other and can described as a smart house which obtains by means of using computer technology and communication. Smart homes designed in mind to increase security, make people's life easier, to make life more comfortable and energy-saving. Speaking refrigerators, self-opening and closing doors, lights flashing, and many more we cannot even imagine etc. control of systems technology products are common fields of all sciences and all engineering fields. For this reason, control systems are very closely related to the working different production processes or worked machinery, electronics, electrical, chemical, aircraft, nuclear engineers. Control techniques which used for control bodies are more directly related to the electrical, electronic and mechanical engineering issues. Using and evaluating of control organs are related with all engineering branches. A case of automation control today is considered one of the most promising areas and emerging as an unlimited growth potential. The use of computers in the control cycle, this issue has become more extensive.

Automation, a system is to manage the specific scenario, without the need for any operator. Scenarios flows are determined by the perceived events and time. In industry automation systems have been used for more than a century. The use of these systems in homes, but it was only thanks to advances in produc-

tion technology. As a result of the market research, the vast majority of the houses has emerged that there is need for home automation systems. In addition home automation systems became apparent to increase energy efficiency, to take security measures against all kinds of problems and works which done several times made automatically. Home automation systems are designed to meet these needs.

With advancing technology using temperature control systems has also increased. We use temperature control systems in our homes ironing, washing machine, water heater, toaster, toaster, heating systems used in industry, cold storage, oil baths, incubators, poultry house, greenhouse and other places. Temperature control systems simplest examples are given. In this study, a model of the house's temperature controls carried out with using PID and timer-based lighting.

Another interesting event is the computer-controlled machines [Karazeybek *Computer...*]. Controllable machines and can be operated by remote control machines facilitate the many offers for people. Studies on control of mechanical systems on the internet and micro computers created a new era of control process. Now people from their homes offices can perform many operations even not going. In light of these developments, it is possible to be controlled to another computer on the internet.

In this study exchanging data with another computer using the Internet-TCP/IP protocol and controlled by means of USB 1208LS device's control pins and this device connected to computer's usb port [Yarım *Robot...*; Yıldırımoğlu 2000]. The software is prepared in C # language and tested.

After the preparation of appropriate software, second stage of the thesis has been passed and connected to the server and circuit design obtained for processing data. First circuit design is prepared on the board and when the circuit seen worked properly after circuit design done on copper plate.

In shortly, in this thesis located any computer is communicated to another computer by means of IP number that is achieved to data changing between these computers. And lots of electronic devices controlled where connected to the opposite computer's Usb port called USB 1208 LS electronic device.

2. Data communication systems and objectives

The main objective of exchange information is to provide data communication, the simplest form; „error-free transmission of data from a source to another source” process can be defined. Data can come back and forth between computers; the data may not be sent to a computer system. Everything that provides communication can be considered as data. The data may not always be a text, image, audio, video, image or the purpose of this thesis, which can be considered as voltage or temperature value in the data. Information can be defined as meaningful data to the people. The important issue in data communication can provide correctly delivery of the data to intended destination. There must be three

main elements to ensure data transmission: to transfer the data in a „transmitter”, to retrieve data from a „receiver”, is used to transmit data between the receiver and the transmitter is a „medium of communication” can be given as [Kaplan 2000].

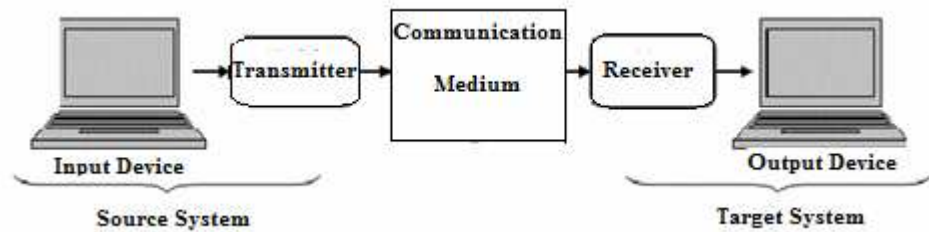

Figure 1. Simply communication system

The computer is a digital media environment; data communication is done via the numeric coding. Transferred data (text or image) coded and transmitted as form of ‘0’ and ‘1’. Thus „data communication” can be explained as exchange of digitally encoded information between computers.

In order to transfer the data over computer networks will have to undergo a series of procedures and controls [Baykal 2001]. To the fulfillment of these processes are taking place at different levels and may require highly complex applications. This all of procedures and controls are occurred data communication system.

3. Communication between computers

Three basic elements are needed for communication between computers.

- The sender (host/source computer) and the receiving computer (target computer), DTE (Data Terminal Equipment – Data Terminal Device) is defined as.
- Interfaces (for example, modem devices, DCE – Data Circuit-Terminating Equipment Data Circuit Finish Tool – is called.)
- Data communication media (cable or satellite connections on) [Çölkesen, Örencik 1999].

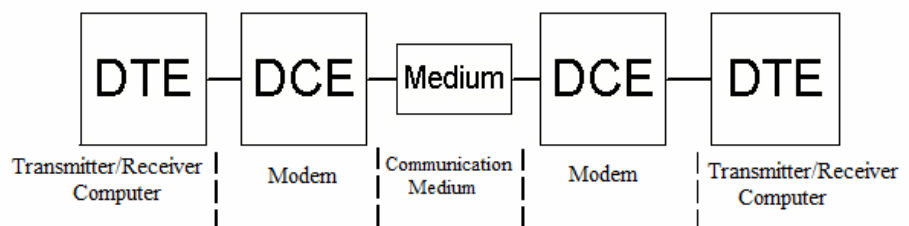

Figure 2. Data communication medium

4. Controlled devices

Smart home technology is used in a home which has home devices and its functions:

- **Television:** Adjust volume and colors according the program and size of space.
- **Refrigerator:** Automatically adjusts cooling and freezing levels according to seasonal differences in usage patterns.
- **Washing machine:** Determines the strategy of washing and drying according to the washing type, quantity and dirtiness.
- **Dishwasher:** Determine washing and polishing strategies based on the amount and rate of dirtiness.
- **Oven:** Cooking time and temperature settings according to the type of material to be cooked.
- **Microwave oven:** energy consumption is keeping minimize according to the material be cooked or heated.



Figure 3. Sample smart home application

- **Vacuum cleaner:** Adjusts power consumption and power of the motor according to the swept the floor and dust suction quantity.
 - **Air conditioning:** Cooling and energy savings are done automatically according to ambient temperature. T also prevents the first start-up unnecessary energy consumption.
 - **Humidification:** Humidity is automatically set according to the needs of the media.
 - **Shower:** Keeping the water temperature fixed and allows you to control the temperature level.
 - **Toast and toasters:** Sets cooking and baking time depending on the type of bread and saves energy.
- Smart house's electrical and electronic aspects are given in figure 3.

5. House features of passed automation

Construction industry in our country has moving days and so it brings competition. People are leaving the normal life home conform and directed towards the safety and equipped with technology houses. Nowadays, the technological characteristics of the houses are a determining factor in purchasing. Thus, according to the specific needs of their users in programmable system and allows you to add modules come to the fore rather than normal programmatic systems. For example, a motion detector system can be used as an alarm trigger when no one at home or can be used the lights burning when entering the room or a person in need of care should be kept under surveillance and if this person is motionless for a long time a motion detector system can be used send notification to the phone or a radio. Also out of the house as a part of the system can perform an active deterrent; in case of approaching danger to the house, activating one of the scenarios and given the impression that someone living in the house. Smart home automation control's most important feature is all kinds of control with a common panel and providing a single system. The remote control can be controlled via the phone or internet [Coşkun, Güney, Eren 2000; Wu, Jan 2003]. Some of the controls programmable automation system:

- Through only one command; take down curtains, dimming lights, runs popcorn machine, take your phone quiet mode, opening the television and DVD player and provide you cinema pleasure at your home.
- Allows you follow the desired area of the house with the desired cameras.
- Turns off all the lights and appliances in the house when you are lying, dims your bedroom light, takes the heater economical position, night mode alarm gets activated at selected regions.
- Lights open automatically in the regions and turn off whenever you leave.
- The house and the water temperature set before setting level when you don't wake up or don't return to home from your work [Coşkun, Güney, Eren 2000]. And provide you find warm home while you don't come to the home.

- One-touches all devices and turns out the lights when leaving the house in the morning, taking the heater economical mode, notify your secretary when you go out your home via internet, phone or text message. And after some time alarm system is taken ‘home free’ mode when you go out of the home.
- Lights, curtains and blinds are set with light sensors’ information depends on the sunrise or sunset time of day.
- When entering the room lights turn on automatically through help of one of the heat-sensitive sensors.
- All the lamps light intensity can be adjusted in the house.
- Wake you and your children at setting time.
- Curtains and blinds are controlled with remote control motors.
- Turn on lamps with 90% brightness in the house and it is useful increasing double the life of light bulbs and also reduces the rate of 30% in energy consumption.
- Such as washing machines and dishwashers consumed more electricity device can work off-peak times in accordance with the smart meters.
- When you are on holiday during certain time periods or suspect person approaches to the home, the system gives the impression that the house is full.
- When you are not at home photographed persons who knocks your door.
- Senses suspicious situation all lights inside and outside can be turned with a single button.
- Alarm can be activated to the desired areas.

6. Electronic devices and materials used in practice

The USB-1208LS is a USB 1.1 low-speed device supported under popular Microsoft, Windows operating systems. It is designed for USB 1.1 ports, and tested for compatibility with both USB 1.1 and USB 2.0 ports. The USB-1208LS features eight analog inputs, two 10-bit analog outputs, 16 digital I/O connections, and one 32-bit external event counter.



Figure 4. Analog/Digital measurement and data processing device

The analog inputs are software configurable for either eight 11-bit single-ended inputs, or four 12-bit differential inputs. The USB-1208LS is powered by the +5 volt USB supply from your computer; no external power is required. I/O connections are made to the device screw terminals [http://www.mccdaq.com/PDFs/specs/USB-1208LS-spec.pdf].

Analog/Digital measurement and information processing device shows a block diagram of the USB-1208LS functions.

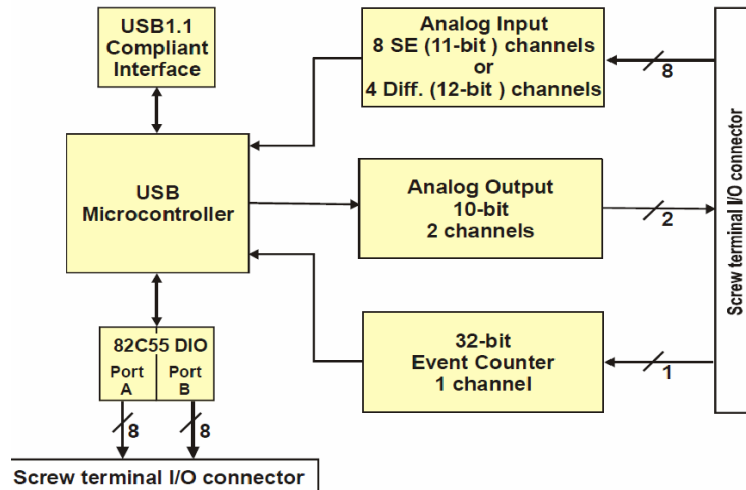

Figure 5. Terminal of USB-1208LS

where, light indicates the device is detected by the computer. Screw terminal wiring (1–20): Used for measurement. Screw terminal wiring (21–40): Can be used to control.

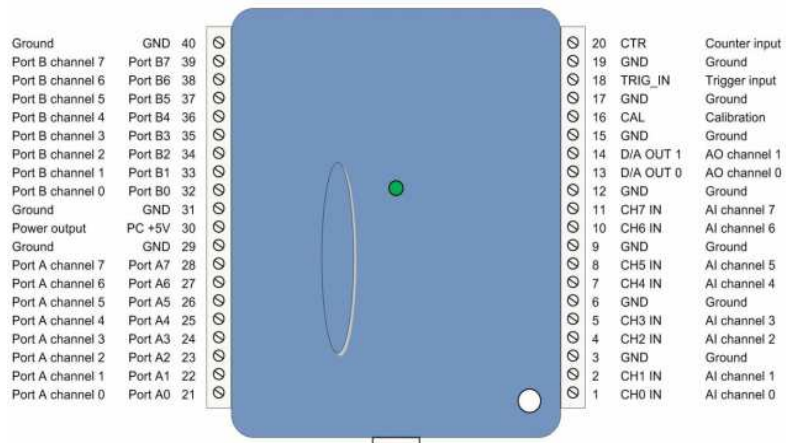

Figure 6. Screw terminal wiring (1–20) (21–40) using 8 different channels

Screw terminal wiring (1–20) (21–40) using 8 different channels are given in figure 6.

Table 1

Screw terminal wiring

Pin	Signal Name	Pin	Signal Name
1	CH0 IN	21	Port A0
2	CH1 IN	22	Port A1
3	GND	23	Port A2
4	CH2 IN	24	Port A3
5	CH3 IN	25	Port A4
6	GND	26	Port A5
7	CH4 IN	27	Port A6
8	CH5 IN	28	Port A7
9	GND	29	GND
10	CH6 IN	30	PC+5V
11	CH7 IN	31	GND
12	GND	32	Port B0
13	D/A OUT 0	33	Port B1
14	D/A OUT 1	34	Port B2
15	GND	35	Port B3
16	CAL	36	Port B4
17	GND	37	Port B5
18	TRIG IN	38	Port B6
19	GND	39	Port B7
20	CTR	40	GND

The device control form screen is given in figure 7 that is using USB-1208LS device. You can give instructions to the device using button 1 and 2. The digital values can be written by text area that is given the below of buttons.

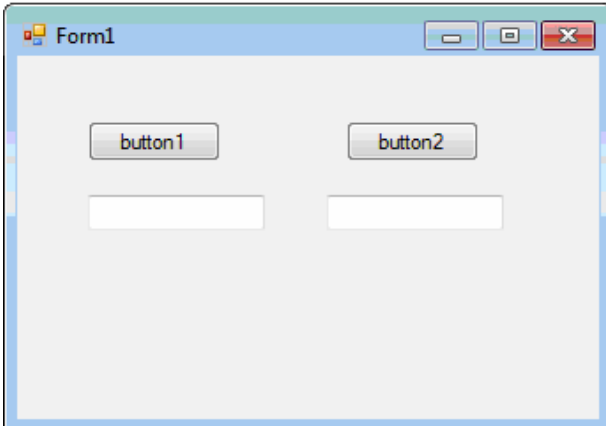

Figure 7. Device control form

Used form in experimental study is given in figure 8. All operators can be connected to the device by IP number and user name. After that, T and Digital values are given using this form.

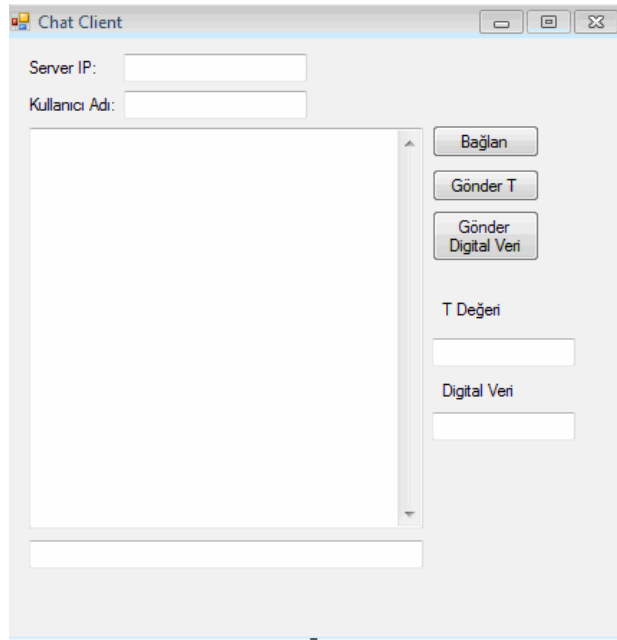

Figure 8. Remote connection program form

Insulation and driver circuit of USB-1208LS device is given in figure 9. The circuit is prepared using Proteus/Isis simulation program.

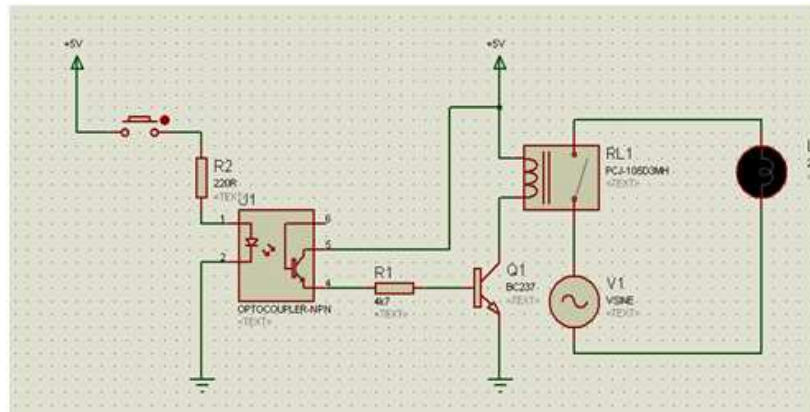

Figure 9. Application circuit of Proteus/Isis

Experimental printed board circuit is shown in figure 10. It is designed by Proteus/Ares printed board program.

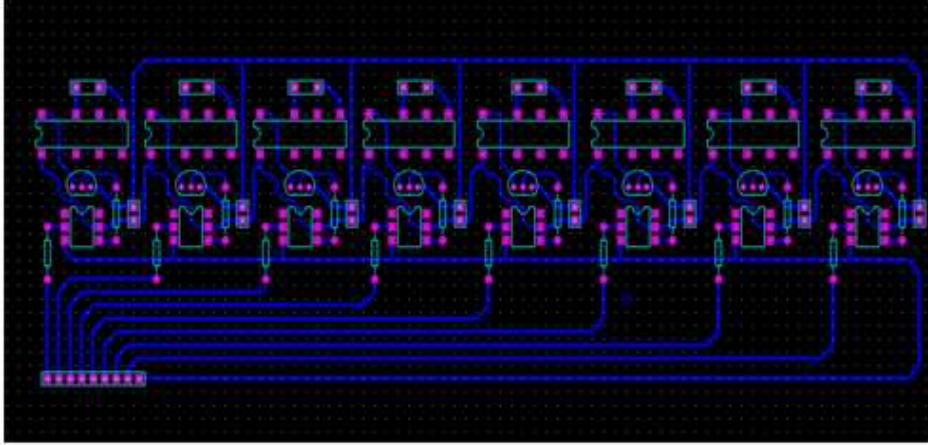

Figure 10. Printed board of Proteus/Ares

The direction of the input and used port that are determined by the program code is written as follows:

```
MccBoard kart = new MccDaq.MccBoard(0);  
DigitalPortType BirinciPort = MccDaq.DigitalPortType.FirstPortA;//kullanılacak portu seçer  
DigitalPortDirection Portyonu = MccDaq.DigitalPortDirection.DigitalIn;//giriş portunun yönü
```

The situation and the output channel of 10 volt device assigns the value of t using below code:

```
durum = kart.VIn(Kanalno, MccDaq.Range.Bip10Volts, out T, secenek);//cihazda duruma 10  
voltluk kanal ve çıkışa t değerini atar  
if (durum.Value = MccDaq.ErrorInfo.ErrorCode.BadRange)  
//eger durum ve mccdaq eşit değilse mesaj kutusuna aşağıdaki mesajı „secilek aralık uygun degil.”,  
„desteklenmeyen aralık” gönder.
```

The below program code shows the value of the port connection:

```
short Digitalveri = 0;  
durum = kart.DIn(BirinciPort, out Digitalveri);  
textBox2.Text = Digitalveri.ToString(); //porttaki bağlantı değerini gösterir.
```

7. Conclusion

The system can be used to control all the systems by giving 10 V_{dc} or 220 V_{rms}. Prepared systems, after editing the required voltage regulation process, is intended to allow control power system in any electronic system. So today smart home automation is slowly starting to break into our daily lives and developed

a method for smart home automation. Prepared this study is to be compatible with the desired any system. For this purpose, when no one is at home you can water your flowers or close the watering system by means of connecting to the internet. For example this study can convert easily watering control system. Before leaving your home you can adjust your office where regulated appropriate voltage process in before, temperature level and is now possible to achieve. It is possible to increase practices in home and industry applications. Development of several projects are possible to achieve with the imagination of the users and can be communicated a web server computer system.

Literature

- Altınbaşak O. (2000), *Mikrodenetleyiciler ve PIC Programlama*, Altaş Yayınları İstanbul.
- Axelsson J. (2000), *Serial Port Complete*, USA.
- Baykal N. (2001), *Bilgisayar Ağları*, SAS Bilişim Yayınları, Ankara.
- Çölkesen, R., Örencik B. (1999), *Bilgisayar Haberleşmesi ve Ağ Teknolojileri*, İstanbul,
- Coşkun O., Güney K., Eren A. (2000), *Telefon Hatları Üzerinden Bilgisayar Yardımıyla Elektronik Sistemlerin Kontrol Edilmesi*, ELECO'2000: Elektrik-Elektronik-Bilgisayar Sempozyumu, Elektronik Bilgisayar, 313–317.
- <http://msdn.microsoft.com>
- <http://www.antrak.org.tr>
- <http://www.mccdaq.com/PDFs/specs/USB-1208LS-spec.pdf>
- <http://www.microchip.com>
- <http://www.mikroelektronika.co.yuT>
- Kaplan Y. (2000), *Veri Haberleşmesi Temelleri*, Papatya Yayınları, İstanbul.
- Karazeybek A., *Computer Controlled Machines*, M.Sc Thesis, Graduate School of Natural and Applied Sciences of Dokuz Eylül University.
- <Thhttp://www.ietf.orgT>
- Wu C., Jan R. (2003), *System Integration Of WAP and SMS For Home Network System*, Department of computer and Information Science, Nationan Chiao Tung University, Computer Networks 42, 493–502.
- Yarım M.A., *Robot Control Over Internet Using Tcp/Ip Protocol*, M.Sc Thesis, Graduate School of Natural and Applied Sciences of Dokuz Eylül University.
- Yıldırımoğlu M. (2000), *TCP/IP İnternet'in Evrensel Dili*, Pusula Yayıncılık.

Abstract

In parallel with developments in technology, home automation systems are being increasingly used. In this study, computer networks and the power system can be controlled by Internet for a remote device. This application was carried out in two stages of software and hardware. The software is developed in C # programming language. This software is connected to the computer using a remote server devices, performed the required information has been sent. The

second part of the application is prepared in the hardware. The information that come to the server Usb can handled and performed by Usb 1208LS. This circuit design performed and connected to the server Usb. After the coming data has been processed, target device which connected to the circuit making power control and commands sent to the device peaks and the application process has been completed the desired.

Key words: remote control, USB DAQ, data communications, computer networks.